



REALPOWER®

OWNER'S MANUAL

RP015 / RP025 / RP036

Real Power
81 W. Kam Drive
Pittsboro, IN 46167
(877) 670-7325
info@realacpower.com
www.realacpower.com

For customer assistance, please call (877) 670-7325

TABLE OF CONTENTS

PATENTED DEVICE.....	3
LIMITED WARRANTY	3
OWNER’S RESPONSIBILITIES	4
LIMITATIONS	4
SAVE THIS MANUAL	5
SAFETY WARNINGS AND PRECAUTIONS.....	6
ELECTRIC GENERATOR SAFETY PRECAUTIONS AND WARNINGS.....	7
COMMON SENSE AND CAUTION PREVAIL.....	7
REAL POWER SYSTEM OVERVIEW	8
RP015, RP025 & RP036 - MECHANICAL REFERENCE DIAGRAM	9
RP015 STANDARD ELECTRICAL PANEL - REFERENCE DIAGRAM	10
RP015 STANDARD ELECTRICAL PANEL - REFERENCE DIAGRAM (INTERNAL)	11
RP036 STANDARD ELECTRICAL PANEL - REFERENCE DIAGRAM.....	12
RP015, RP025 & RP036 ELECTRICAL LIMITATIONS AND CAPABILITIES	13
DSR REGULATOR DIAGRAM	14
OPERATION	15
MAINTENANCE.....	17
TROUBLE SHOOTING.....	27
ENVIRONMENTAL IMPACT ON ELECTRICAL PERFORMANCE	28
UNAUTHORIZED AND UNTESTED USE - MISUSE.....	28

COPYRIGHT © 2022 by Contour Hardening, Inc. All rights reserved. No portion of this manual or any artwork contained herein may be reproduced in any shape or form without the express written consent of Contour Hardening, Inc. **REALPOWER**® is a trademark of Contour Hardening, Inc.

PATENTED DEVICE

The following patents issued by the United States Patent and Trademark Office cover the Real Power™ chassis integrated AC generation system and/or the methods for using it:

US Patent # 6,979,913

US Patent # 7,057,303

Patent Application 2021/0316617 A1 filed 10/14/21

LIMITED WARRANTY

Contour Hardening Inc. (CHI) hereby warrants to the Purchaser of the Real Power™ chassis integrated AC generator system (SYSTEM) that the System will be free of defects in material and workmanship from the date of installation marked on the warranty registration card or other written documents that independently collaborate the installation date. If the installation date cannot be verified the warranty will begin 30 days after the date of shipment from CHI as follows:

All rotating parts and components:	1 year
Electrical Distribution-Outlet box and components therein:	1 year
Repair or replacements parts:	90 days*
Paint or coating on all components:	NOT WARRANTED

PROVIDED that the System is operated in accordance with the operating instructions included with all shipments. CHI may require reasonable proof of date of purchase. THEREFORE, PURCHASER SHOULD RETAIN THE SALES RECEIPT OR INVOICE.

Defective parts must be returned to CHI for inspection before they can be covered under this warranty. Parts or a System returned to CHI without prior authorization will not be accepted. After CHI **confirms** the defect **and approves** the warranty claim, CHI will authorize the replacement of the defective part(s). For confirmed and approved warranted repairs, CHI will pay for the parts to repair or replace the defective parts or System. **CHI will not pay for labor to disassemble** or reassemble the System unless the system was installed by CHI and it is still under warranty. Systems installed by CHI must be repaired by CHI in Indianapolis, Indiana for disassembly and reassembly to be covered under warranty.

CHI retains the right to make ALL subjective decisions regarding warranty claims.

Labor to repair or replace parts will occur only during normal business hours, overtime to expedite repair or replacement will not be covered under warranty.

Any and all **labor** provided by the purchaser, an agent of the purchaser or any other party other than CHI, either during the original installation or repair, is **not covered under CHI's warranty**.

** Repair or replacement parts are also warranted for ninety (90) days from the date of shipment from CHI. Any part repaired or replaced during the warranty period assumes the remainder of the original System warranty or ninety (90) days, whichever is greater.*

OWNER'S RESPONSIBILITIES

Purchaser is obligated to operate and maintain the System in accordance with the recommendations and instructions contained herein. Purchaser is responsible for the costs associated with such use, maintenance and adjustments that may be required.

All warranty claims must be brought to CHI's attention within a reasonable time, preferably within thirty (30) days, after discovery that the System fails to meet this warranty.

Purchaser is responsible for payment of any of the following expenses that might be incurred as a result of a failure under the terms of this Limited Warranty:

1. **Shipping or delivery** to Real Power for vehicles or parts covered under this warranty;
2. rental equipment used to replace the System or the vehicle on which the System is mounted during the time the System and vehicle are being repaired;
3. telephone and other communication expenses;
4. living and travel expenses;
5. the premium costs for overtime labor requested by the Purchaser to expedite the repair;
6. the cost of airfreight or other extraordinary expenses for shipment of parts over and above premium surface transportation;
7. failures due to normal wear or excessive wear, lack of reasonable and necessary maintenance, accident, misuse, abuse, negligence in operation or maintenance, unauthorized modifications or repairs, use of add-on or modified parts not supplied by CHI, improper storage, vandalism, and improper installation or improper maintenance or service;
8. transportation of vehicle to designated repair facility; and
9. failures due to electrical overload or short circuits.

LIMITATIONS

This Limited Warranty shall be limited to the repair or replacement of parts that prove defective under **normal use** and service and which upon examination shall indicate to CHI's satisfaction they are defective. This Limited Warranty will not cover repair where normal use has exhausted the life of a part of the System or the entire System. Like all other mechanical devices, this System needs periodic parts replaced and service to perform well. The service life of the System is dependent on the care that it receives and the conditions under which it operates. Extreme heat and/or dusty or dirty conditions can cause excessive wear. **EXCESSIVE WEAR, when caused by improper maintenance or operation, is NOT COVERED by this Limited Warranty.**

Use of this System on a **vehicle used for snow removal** causes excessive wear and is **not covered under this warranty.**

This Limited Warranty does NOT cover any failures or operating difficulties due directly or indirectly to normal or excessive wear, collision, negligence or accidents, abuse, misuse, unauthorized modifications – alterations – or the use of add-on or modified parts not supplied by CHI, vandalism, improper installation or improper maintenance or service, or failure to perform normal and routine maintenance. Deterioration or damage due to severe weather conditions such and hurricanes, earthquakes or tornadoes and exposure to corrosive chemicals either direct or in the atmosphere, is not covered by this Limited Warranty. Damage associated with ground clearance under the vehicle is not covered by this Limited Warranty.

THERE ARE NO **OTHER EXPRESS WARRANTIES** and any applicable implied warranties of merchantability and fitness for a particular purpose are limited in duration to the period of coverage of this express written Limited Warranty. **TO THE EXTENT PERMITTED BY LAW, ANY AND ALL IMPLIED WARRANTIES ARE EXCLUDED.** Some regions do not allow limitation on how long an implied warranty lasts, so this limitation may not apply to Purchaser.

CHI is **NOT LIABLE** for any special, incidental, indirect, contingent, or consequential damages arising from the use of the System. Some regions do not allow limitation or exclusion of incidental or consequential damages, so this limitation may not apply to Purchaser.

This Limited Warranty gives you specific legal rights. You may also have other rights that may vary from state to state or province.

CHI does NOT authorize any person or company to assume for it any other obligation or liability in connection with the sale, installation, use, removal, return, or replacement of its equipment; and no such representations are binding on CHI.

CHI MAKES NO REPRESENTATION OR WARRANTY OF ANY KIND TO THE PURCHASER THAT HE OR SHE IS QUALIFIED TO MAKE ANY REPAIRS TO THE SYSTEM OR THAT HE OR SHE IS QUALIFIED TO REPLACE ANY PARTS OF THE SYSTEM. THE PURCHASER ASSUMES ALL RISK AND LIABILITY ARISING OUT OF HIS OR HER REPAIRS TO THE SYSTEM OR REPLACEMENT PARTS THERETO, OR ARISING OUT OF HIS OR HER INSTALLATION OF REPLACEMENT PARTS THERETO.

THIS LIMITED WARRANTY ONLY APPLIES TO SYSTEMS SOLD AT RETAIL.

SAVE THIS MANUAL

You will need the manual for the safety warnings and precautions, assembly instructions, operating and maintenance procedures, parts list, and diagram. Keep your invoice with this manual. Write the invoice number on the inside of the front cover. Keep the manual and invoice in a safe and dry place for future reference.

SAFETY WARNINGS AND PRECAUTIONS



WARNING:

When using Real Power, basic safety precautions should always be followed to reduce the risk of personal injury and damage to equipment.

Read all instructions before using this system!

1. **Observe work area conditions.** Do not use electricity or power tools in damp or wet locations. Keep work area well lighted. Do not use electrically powered tools in the presence of flammable gases or liquids.
2. **Keep unauthorized personnel and children away from the vehicle.** The Real Power system contains rotating components and lethal voltages. Only trained personnel should be allowed near the vehicle while the system is operating.
3. Lethal voltage is present whenever the system is operating. Real Power generators can produce voltages in excess of 480V.



4. **Dress properly.** Do not wear loose clothing or jewelry as they can be caught in moving parts. Protective, electrically non-conductive clothes and non-skid footwear are recommended when working. Wear restrictive hair covering to contain long hair.



5. Do not go under vehicle when System or engine is running. Do not work on or near an exposed shaft while the engine is running.
6. **Do not overreach.** Keep proper footing and balance at all times. Do not reach over or across running machines.
7. **Do not start or stop the generator with a load connected.** Unplug connected tools, appliances and cords when not in use and prior to starting or stopping the System.
8. **Check for damaged parts.** Before using the Real Power system inspect it thoroughly. Make sure all bolts are tight. The generator should be dry and free of debris.
9. **Replacement parts and accessories.** When servicing, use only identical replacement parts. Use of any other parts will void the warranty. Replacement parts and service are available from Real Power. You contact us by calling (877) 670-7325. Parts and accessories should be installed by qualified technicians.
10. **Do not operate a Real Power system if under the influence of alcohol or drugs.** Read warning labels on prescriptions to determine if your judgment or reflexes are impaired while taking drugs. If there is any doubt, do not operate the system.
11. **Use proper size and type cable.** Follow Local and National Electric Code guidelines when connecting loads to the generator.

ELECTRIC GENERATOR SAFETY PRECAUTIONS AND WARNINGS



WARNING: When System is operating, lethal voltage is present!

1. The generator produces electrical current. Improper use can result in electrocution, injury or death. Only a qualified technician should service or repair this generator.
2. The generator was designed to be used in a dry area. Use extreme caution when operating the System in rain, snow, sleet, or damp conditions. Operating the System in such conditions is NEVER recommended or encouraged. Moisture can carry electrical current and could cause electrocution.
3. If the generator is connected to a building, home, business, or any other electrical circuit normally fed by utility power, steps must be taken to ensure that the generator output and the utility power are isolated. Failure to isolate the systems could result in personal injury or death to those working around these circuits. Any connection in this regard must only be done in accordance with NEC or the locally applicable Electrical Code.
4. Do not exceed the generator's rated capacity. The total electrical loads must be added to determine the total electrical load. If the electrical appliance does not list the wattage rating, you can calculate it by multiplying amps times voltage (amps x voltage = watts).
5. Do not tamper with the drive engine-governed speed. The generator is designed to operate at a set speed. Changing this speed will change the output voltage and frequency. Increases in speed will damage rotating parts of the generator. Slower speeds may damage the generator or appliances connected to the generator due to low voltage.
6. Always follow national and local safety codes.
7. Do not start or stop the System with equipment connected and turned on.
8. Do not operate your Real Power equipped vehicle in an enclosed area due to the carbon monoxide fumes produced. The fumes are colorless and odorless and are deadly.
9. Never handle electrical equipment or cords while standing in water.
10. Only use 3-prong, grounded extension cords.
11. Keep fingers, hands, cords and other loose items away from the spinning shafts and pulleys that are rotating under your Real Power equipped vehicle.
12. Never refuel or add fuel to your vehicle or remove the fuel cap whenever the System is operating.
13. Read, understand, and follow all safety precautions in your vehicle owner's manual prior to running the System.

COMMON SENSE AND CAUTION PREVAIL

The warnings, cautions, and instructions discussed in this manual cannot cover all possible conditions and situations that may occur. It must be understood by the operator that common sense and caution are factors that cannot be built into this product, but must be supplied by the operator.

REAL POWER SYSTEM OVERVIEW

Real Power generator systems are manufactured exclusively for use with the power take off (PTO) of a Class 4 or larger work truck with diesel engine and automatic transmission. While in a parked, stationary mode, the engine of the truck provides rotational power to the generator via the PTO attachment, turning it at a constant 1800 RPM to produce 60Hz. The truck engine RPM, power output, and torque are controlled automatically by the truck ECM and TCM with no input required from the user.



Power from the generator is typically routed to a remote electrical panel box, located in the body of the truck, which contains both the low voltage DC control signals and the high voltage AC power distribution with main breaker, sub breakers, and either plug-in receptacles or hard wire lines for other equipment.

While the standard RP015 generators ship with dedicated 240/120V 1 Φ wiring, the RP036 systems provided by Real Power have an industry-standard 12 wire reconnectable configuration, capable of 480V 3 Φ , 208V 3 Φ , or 240/120V 1 Φ depending on how they are tapped. All Real Power generators are equipped with a proprietary set of enhancements to make them robust against difficult road environments.

A diagram showing the connection options is provided with each system. All connections to the generator should be done in accordance with NEC guidelines and any other applicable electrical code for your area.

RP015 & RP036 - MECHANICAL REFERENCE DIAGRAM

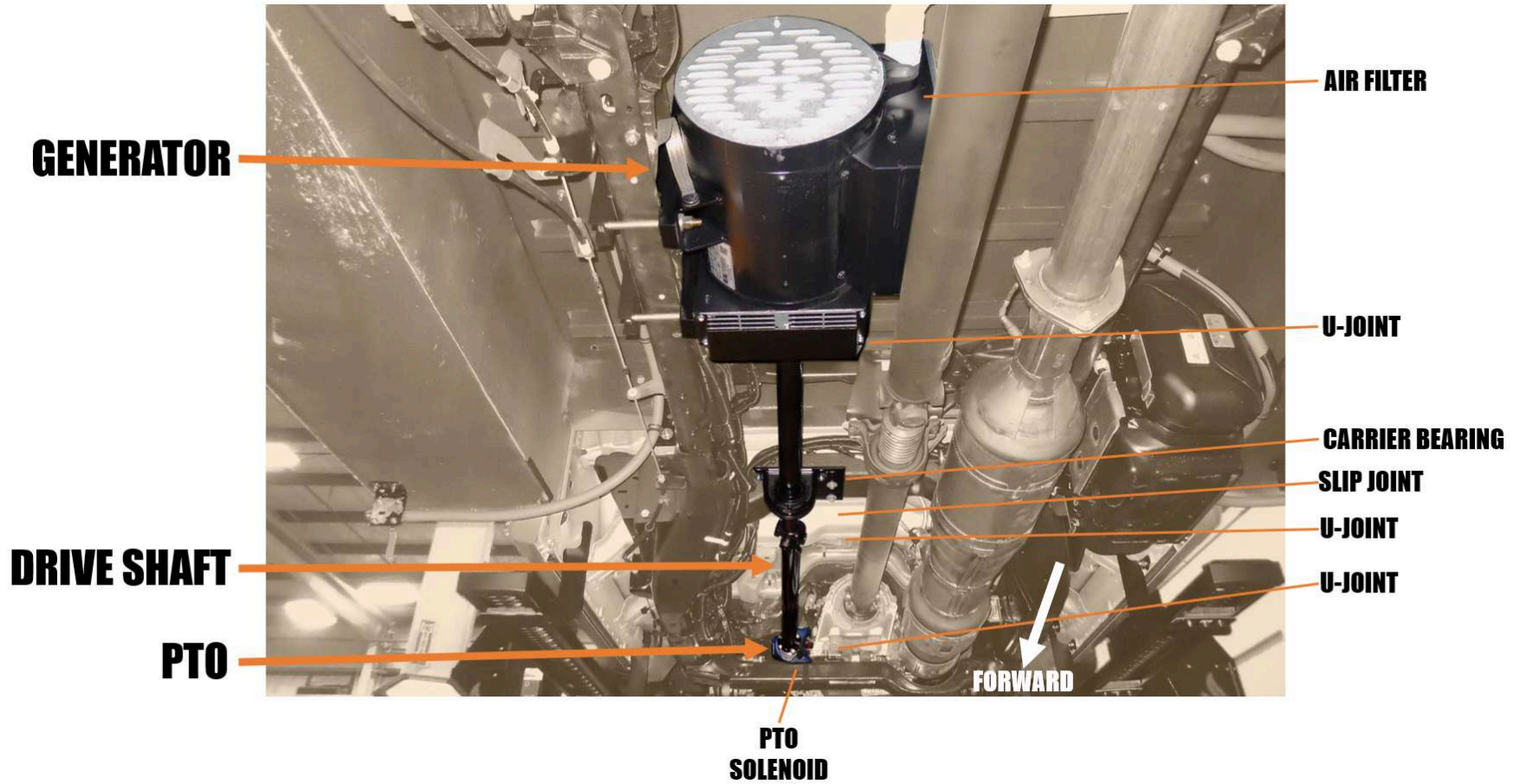

Notes:

1. This diagram is intended to help the reader familiarize themselves with the generator mechanicals. There is some variability between trucks depending on model year, wheelbase, and body style.
2. 4x4 Vehicles have an added Live Drive transfer case adapter (not pictured here) allowing the drive shaft to pass through.

RP015 STANDARD ELECTRICAL PANEL - REFERENCE DIAGRAM

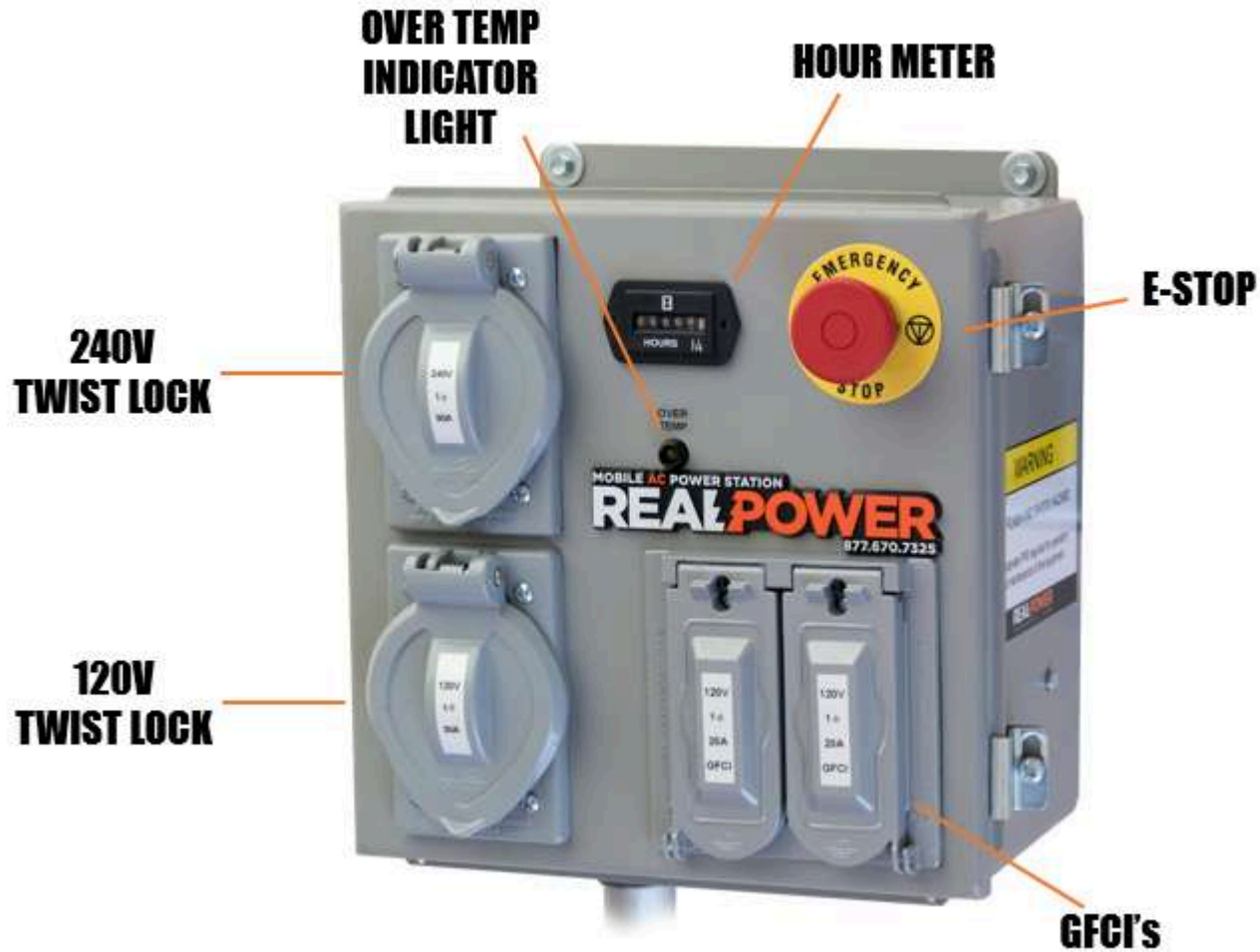

Notes:

1. This diagram is intended to help the reader familiarize themselves with the standard Real Power electrical panel. Exact design will vary by generator size and specification. Always take care to use proper electrical safety procedures when using any connection panel.
2. To reset E-Stop, pull red knob out.

RP015 STANDARD ELECTRICAL PANEL - REFERENCE DIAGRAM (INTERNAL)

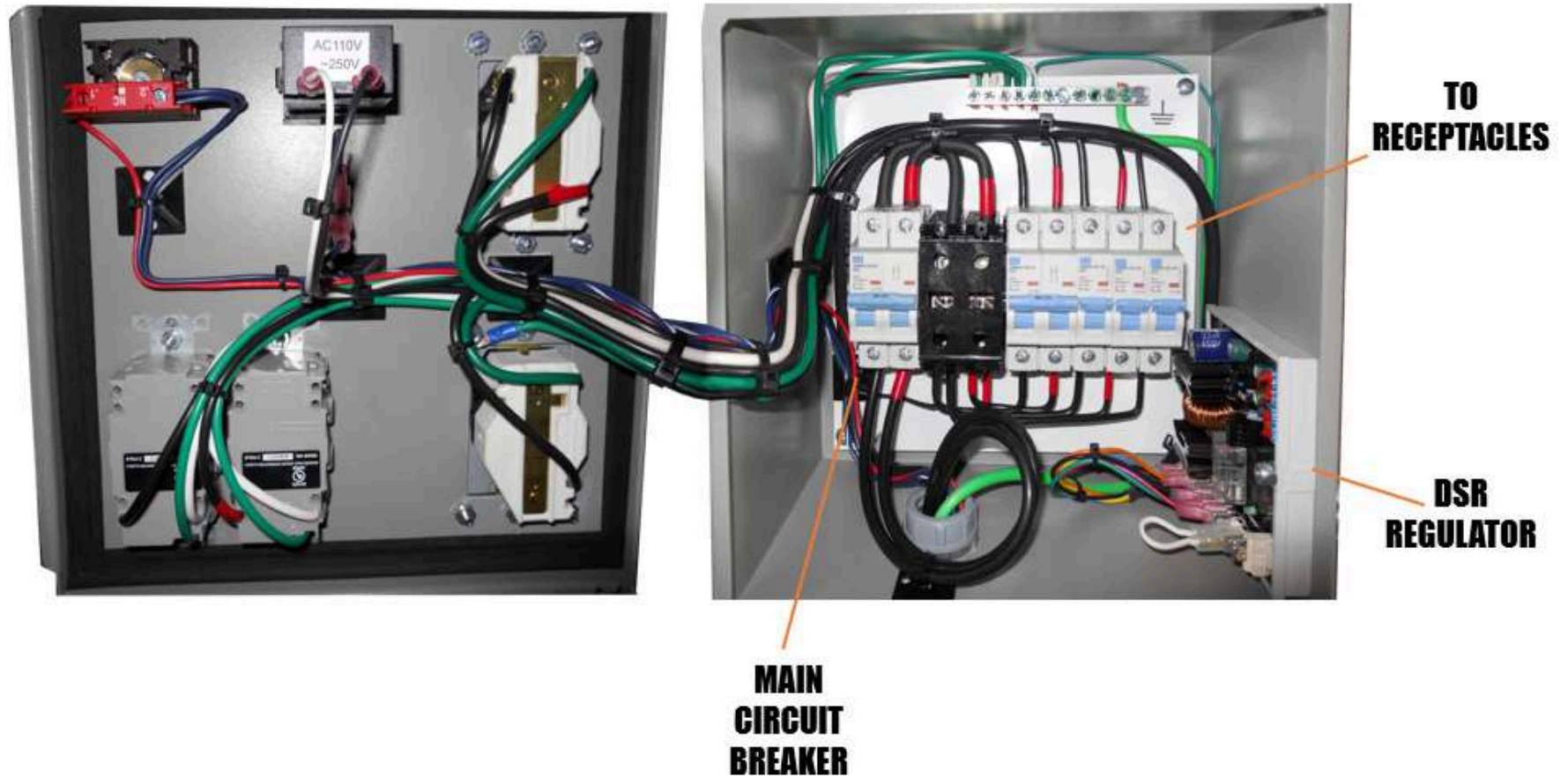

Notes:

This diagram is intended to help the reader familiarize themselves with the standard Real Power electrical panel. Exact design will vary by generator size and specification. Always take care to use proper electrical safety procedures when using any connection panel.

RP036 STANDARD ELECTRICAL PANEL - REFERENCE DIAGRAM

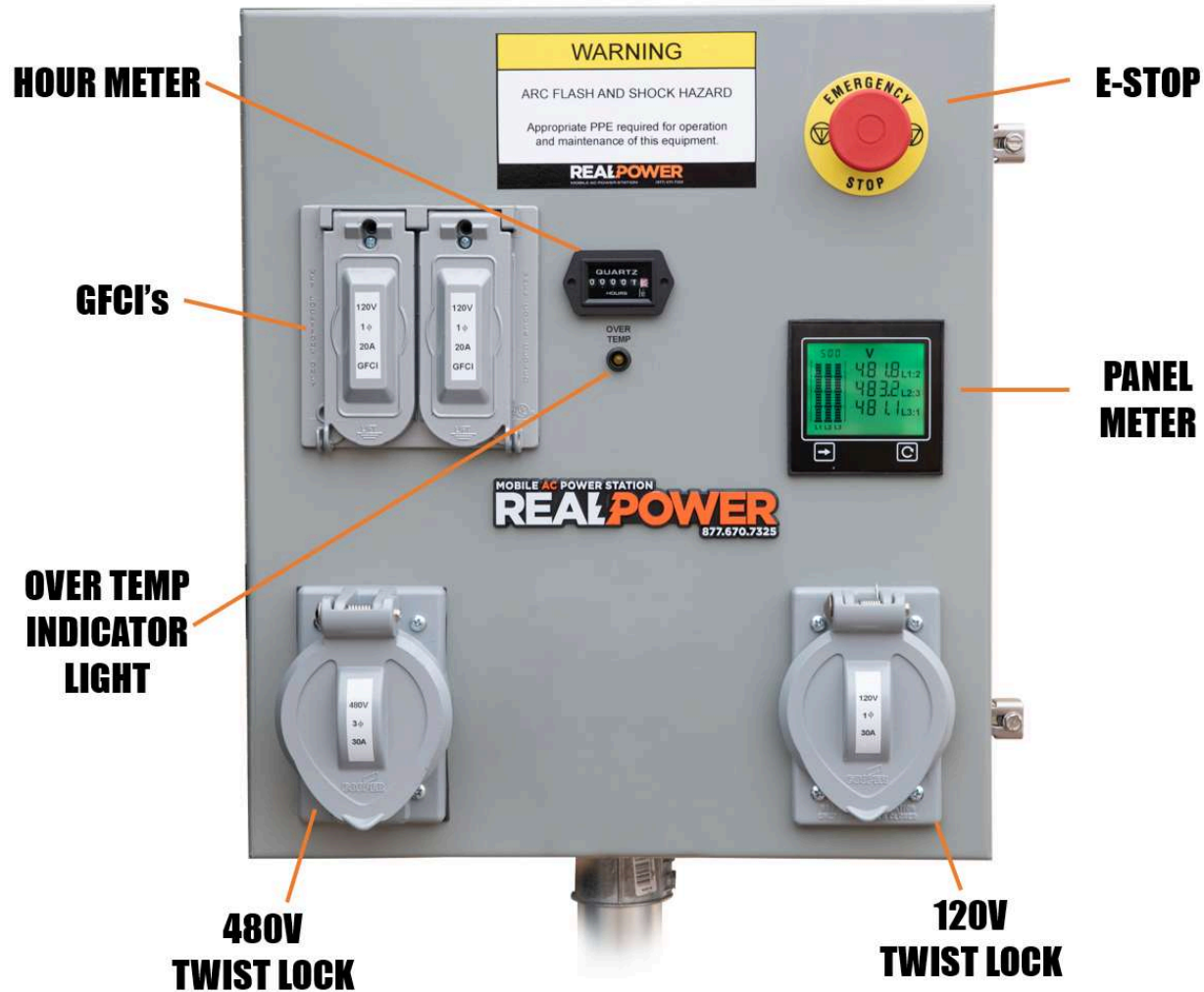

Notes:

1. This diagram is intended to help the reader familiarize themselves with the standard Real Power electrical panel. Exact design will vary by generator size and specification. Always take care to use proper electrical safety procedures when using any connection panel.
2. To reset E-Stop, pull red knob out.

RP015 & RP036 ELECTRICAL LIMITATIONS AND CAPABILITIES

Series Star Y	Parallel Star y	Series Delta Δ	Parallel Delta Δ	Zig Zag Z	RP Model	RP015	RP036
480V 3φ / 277 3φ	240V 3φ / 138V 3φ	277V 3φ / 138V 2φ	138V 3φ	-	kVA kW 480V Max Amps	N/A N/A N/A	36.6 29 44
416V 3φ / 240V 3φ	208V 3φ / 120V 3φ	240V 3φ / 120V 2φ	120V 3φ	-	kVA kW 208V Max Amps	N/A N/A N/A	33 26 92
-	-	-	-	240V 1φ / 120V 2φ	kVA kW 240V Max Amps	N/A 15 63	N/A 22 92

Notes:

The capacities listed in this table pertain to maximum continuous generator capacity at 60Hz, at sea level with up to 125C temperature rise. Power factor (PF) is assumed to be 0.8 when converting kVA to kW.

DSR REGULATOR DIAGRAM

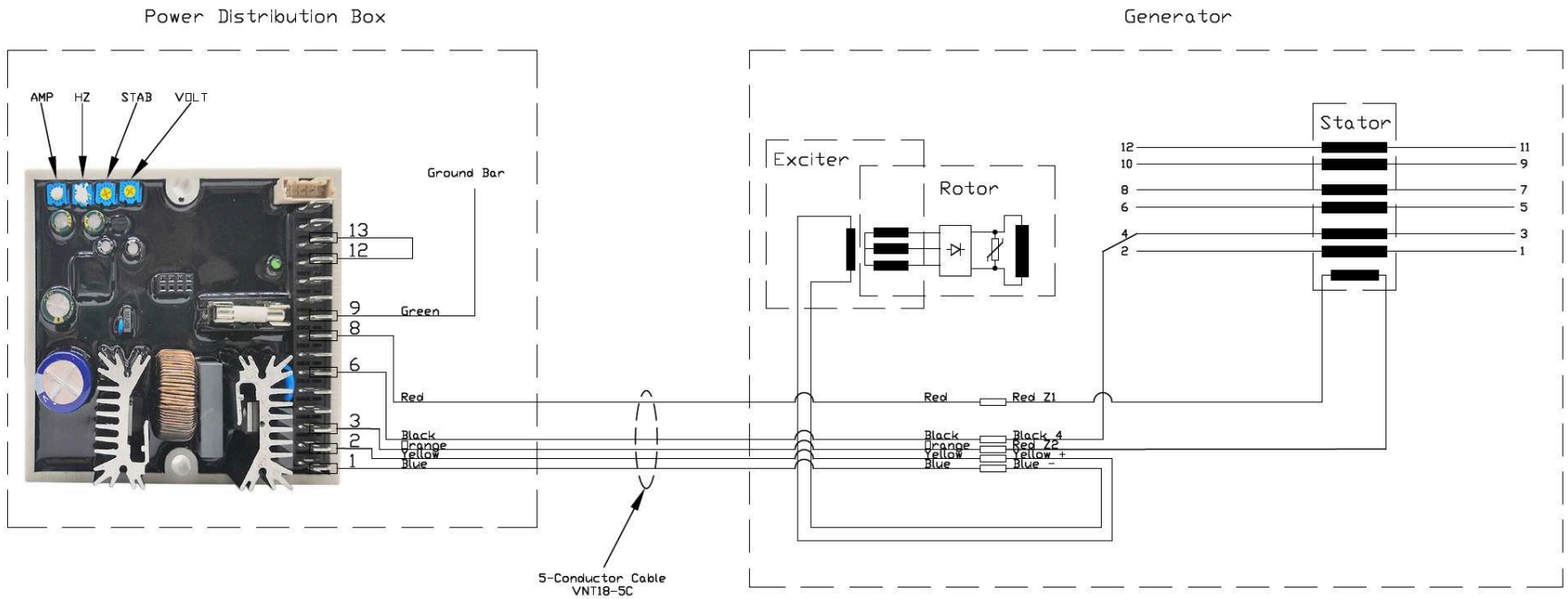

Notes:

All Real Power generators are 4-pole, brushless, 1800 rpm AC generators with digital voltage regulation. The regulators are located inside the main connection panel and include 4 potentiometer adjustments. The only adjustment that should ever be made to the regulator once it has been installed is the VOLT setting. All others are set by the factory.

OPERATION



WARNING: Custom applications may have slightly different instructions. If you have any questions contact your installer or Real Power.

Warm Up and Cool Down

The generator should be allowed to warm up before use when the weather is cold. This allows the system to reach operating temperature before the components are stressed with a load. For temperatures at or below 32°F the system should be allowed to warm up for approximately 10 minutes. When the weather is hot or the generator is used under heavy load the system needs time to cool down. This can be done by leaving the truck idling for 10 minutes with the PTO engaged allowing the integrated generator fan to cool down the generator. Approximately a 10 minute cool down period is recommended if the air temperature is greater than 80°F or if the generator is used at greater than 80% load.

Starting the Generator

1. Verify that there is no load on the generator. All equipment should be unplugged or off.
2. Confirm that the E-Stop switch on the panel is reset (pulled out).
3. Ensure truck is in Park
4. Set Parking Brake
5. Turn the Ignition Key if vehicle is not running. (Truck does not need to be turned off and on.)
6. Set upfitter switch labeled "PTO"



PTO Clutch will automatically engage. Engine RPM will automatically ramp to the correct speed and hold there.

7. Allow the generator to warm up if necessary. (see above Warm Up and Cool Down section)
8. The generator is ready to supply power.

Stopping the Generator

The normal procedure for shutting down the generator is as follows:

1. Remove all loads from the generator. All equipment should be unplugged or in off position.
2. Return PTO switch to off.
3. Reset Parking Brake.
4. Allow the generator a few seconds to spin down and come to a rest before moving the vehicle.

Resettable PTO Interrupts [Does Not Require System to be Turned Off and On Again]

The command signal for the vehicle to run PTO mode and engage the generator passes through all three of these checks in series. Removing any one of them will shut off the generator system. If the truck is running, it will immediately restart the generator once the interrupt is restored.

1. PTO Upfitter Switch
2. Real Power Emergency Stop Button
3. Generator Over-Temperature Switch

Note: The order in which these signals are engaged or disengaged does not affect operation. For example, if the Over Temperature Switch shuts the PTO off but the PTO dash switch remains engaged with the engine on, the generator system will automatically come back on (whether intentional or not) once the temperature switch resets. The same is true for the Emergency Stop, but it should be noted: Real Power recommends always using the PTO upfitter switch to operate the generator rather than the emergency stop.

Stationary Elevated Idle Control (SEIC) program interrupts [Requires System to be Turned Off and On Again]

In addition to the PTO enable command signal, there are a number of fault conditions that will cause the truck to shut down the PTO and high idle internally. Once they occur, the command signal must be cycled by switching the PTO switch off and on again. Fault conditions include:

1. Pressing the foot brake pedal
2. Shifting out of Park
3. Releasing the Parking Brake
4. Pressing the accelerator pedal
5. Vehicle rolling / motion
6. Over temperature of the engine or transmission coolant

REAL POWER Secure Truck Feature

All Real Power generators installed on Ford and Dodge trucks come equipped with the Real Power Secure Truck feature, which allows the PTO, once engaged, to continue to run even after the ignition key is turned off and removed. At any time that the generator is running, the operator may remove the key from the truck and lock the doors behind him, allowing him to work on power equipment hundreds of feet away without concern for the security of the vehicle.

PTO operation will continue unless and until any one of the above interrupts is engaged or a fault condition occurs. At that time, the vehicle will shut down completely, including the engine and be inoperable until the key is put into the ignition and turned back to start up. Alternatively, an operator can put the key back in the ignition while the generator is still running and return it to the RUN position. Then the truck will not shut down when the PTO is turned off.

Periodic Cycling

The Real Power generator system should be started and ran for 10 minutes once every 30 days if not used regularly. This will cycle the shaft and bearings and keep them lubricated.

MAINTENANCE

In order to ensure proper functioning of your Real Power Generator and prevent possible damage to your vehicle, it is paramount to conduct regular checks and perform preventative maintenance actions on your generator, the driveline, and PTO. Make sure to keep records of maintenance activities that are conducted. Failure to properly maintain your generator system could void the warranty.



WARNING: Before performing any maintenance on any portion of the Real Power generation system, the vehicle must be off with the keys removed from the ignition and the generator and all parts of the vehicle must be allowed to cool down after use.

Item	Component(s)	Maintenance Item	Frequency
1	Live Drive	Lubricate 4x4 Ball Joint	60hrs / 1 Month
2	Live Drive	Lubricate 4x4 Pillow Block Zerk Fitting	100hrs / 1 Month
3	Drive Shaft	Lubricate Slip Joint Zerk Fitting	100hrs / 1 Month
4	Drive Shaft	Inspect U-Joints and Carrier Bearing	100hrs / 1 Month
5	Drive Shaft & PTO	Check paint indicators on fasteners	100hrs / 1 Month
6	PTO & Generator	Free Rotation Check	100hrs / 1 Month
7	Generator	Remove and Wash Air Filter	300 hrs
8	Generator	Full visual inspection	1 year
9	Drive Shaft	Full visual inspection	1 year
10	Drive Shaft & PTO	Check fasteners	1 year
11	Panel	Internal Inspection	1 year
12	Truck	Engine Oil Change	5000-7500 miles*
13	Truck	Fuel Filter	15,000 – 25,000miles**

*As indicated by vehicle oil life monitoring system

**Include generator hours x 50 miles/hr calculation

1. Real Power drivelines connecting the PTO to the Generator are generally equipped with Sealed, Non-Serviceable U-joints which do not have grease fittings. However, 4x4 vehicles have a driveline with a CV joint attached to the back of the transfer case which does have a greaseable ball joint in the center.

This joint must be lubricated monthly or every 50-60 hrs, whichever is more frequent. To do so, use a needle-nose grease point to inject directly into the fitting at the center of the CV joint.

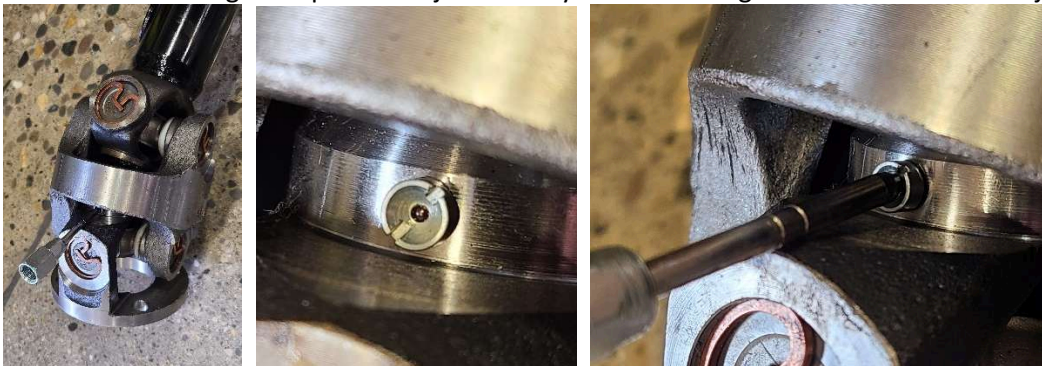

From the manufacturer:

Dana recommends lubrication with Spicer ultra-premium synthetic grease, Chevron Ultra-Duty EP-2, or a compatible lithium-based grease meeting NLGI Grade 2 and ASTM D4950 LB specifications. Spicer ultra-premium synthetic grease is available in 10-packs of 14-oz. tubes (SPL1051) and 1-gal. pails (SPL1052)

NOTE: TO EFFECTIVELY ENSURE GREASE IS ENTERING AND FLUSHING THE CV BEARING, OPERATORS MUST USE AN ELECTRIC GREASE GUN WITH CORRECT TIP.



Milwaukee M12 Cordless



LNL 122 Narrow Needle

Once new grease is added to fitting (blue arrow), check to ensure that excess grease is leaving out the port in the center (yellow arrow). If grease appears around the fitting, it did not go into the joint.

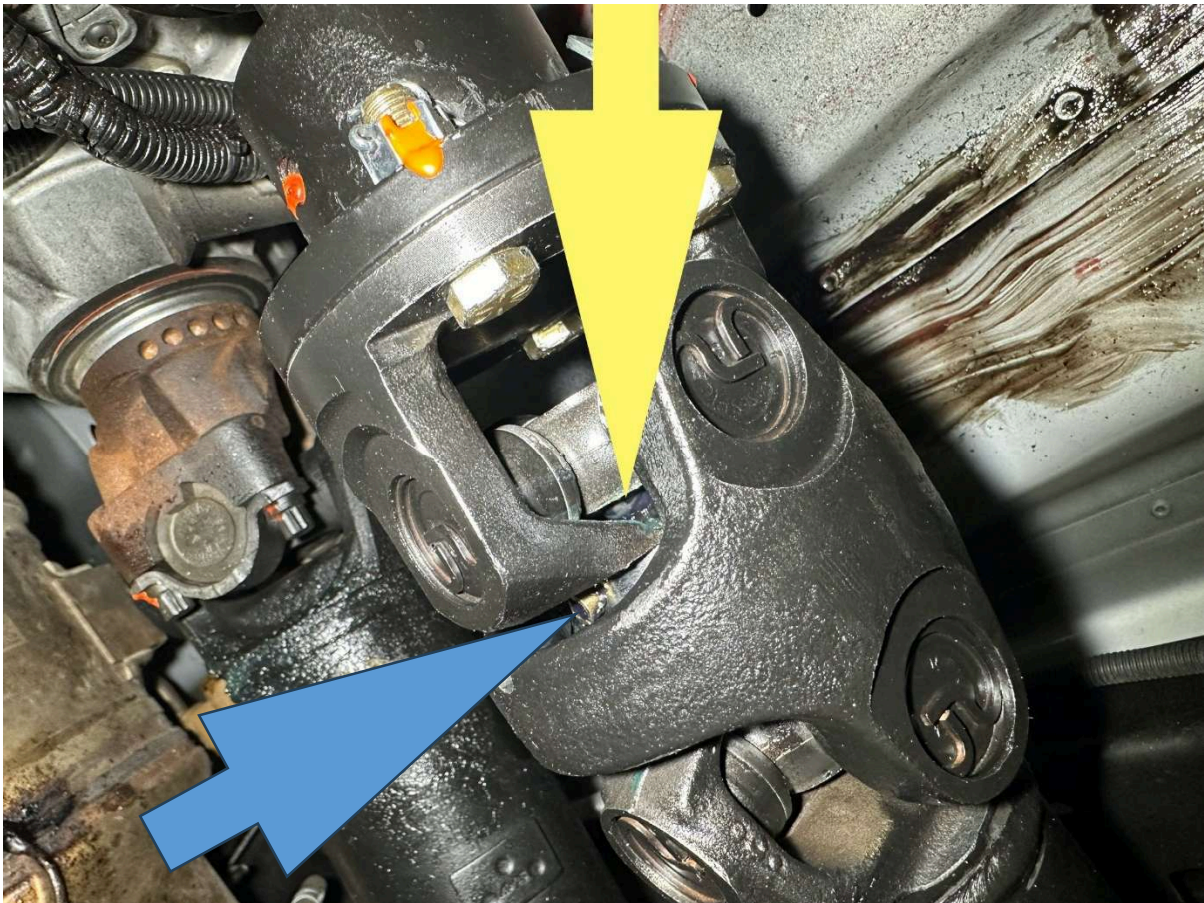

Note: In some applications, 4x4 drivelines use greasable U-joints along with the greasable ball joint. If you have a 4x4 truck, familiarize yourself with your configuration.

- 4x4 Trucks are also built with a pillow-block style bearing, mounted to the back of the transfer case. It has a zerk fitting that must be lubricated every 100hrs or 1 month.

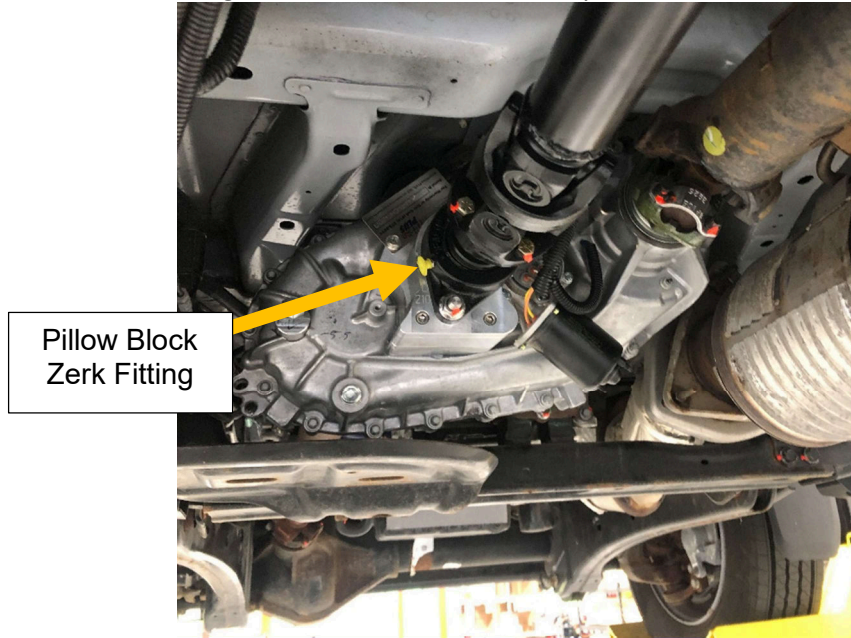

- All Real Power systems have a slip joint in the center with its own zerk fitting. This must be lubricated every 100hrs or 1 month.



4. To ensure the safe and reliable operation of the drive shafts, the U-joints must be inspected monthly or every 100 hours. Visually inspect the 4 cups of each U-joint for signs of heat damage, slop, or water penetration. Snap rings should all be snug in place without any visible cracks. The drive joint should have no play in it and be able to rotate smoothly by hand.



Above: 1. A new U-joint. 2. Good U-joint – clean and sealed with smooth rotation. 3. Bad U-joint – Rusted out with gritty motion and/or slop in the joints.

Check for a characteristic pattern of grease spatter which could indicate that the seals are failing and grease is leaking out. NOTE: if your vehicle has greasable U-joints and a CV joint, it is normal to have some amount of spatter from those fittings.



Similarly, the carrier bearing mount should be firmly holding the driveline collar in place without slop or free motion. Check seals for separation or degradation.

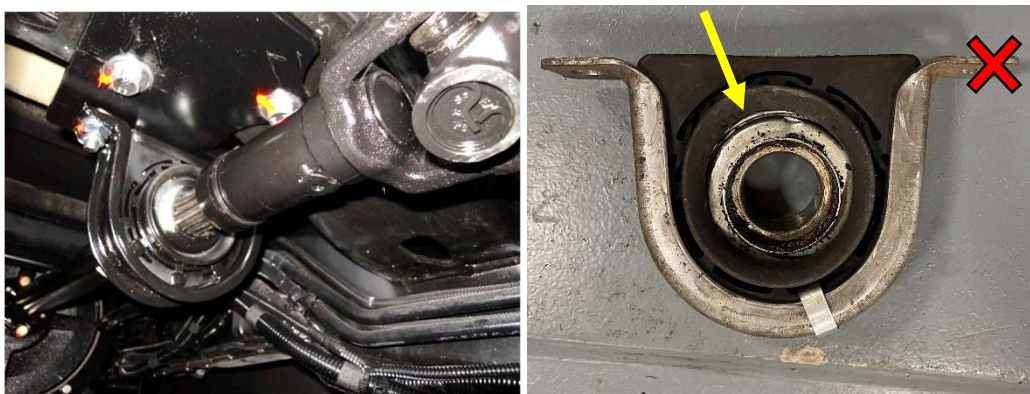

Above: 1. New Carrier Bearing. 2. Bad carrier bearing with torn rubber and displaced front seal.

If any issues are found, the U-joints or drive line may need to be replaced. Contact Real Power for help determining a course of action.

5. All fasteners have been marked with tamper evident paint. Every 100 hrs or 1 month, check all marks for signs of movement or loosening. If found, immediately retighten and make a note to track possible future issues.

NOTE: Take special notice of the PTO mounting bolts. If PTO comes partially loose during operation, catastrophic failure to transmission could occur.



6. When the truck is off, the driveshaft should rotate freely and smoothly. Every 100hrs or 1 month, rotate the drive shaft by hand and check the PTO and generator for smooth, even rotation. Take note of bearing friction, noise, or roughness and contact Real Power in the event of a substantial or worsening noise and/or roughness on either end of the drive line.

7. The air filter on the generator should be periodically cleaned. Inspect the air filter every 300 hours and make sure it is not clogged.

i. Remove the rear dust cover on the generator with 10mm socket.



ii. Wash the filter with warm water and mild soap.



iii. Allow the filter to dry.

iv. Re-install the filter and dust cover.

8. Once per year, conduct a thorough inspection of the generator. Look for signs of loosening hardware, signs of wear or abrasion on the conduit leaving the generator, or rubbing between the generator fan shroud or output box and the truck's driveline.

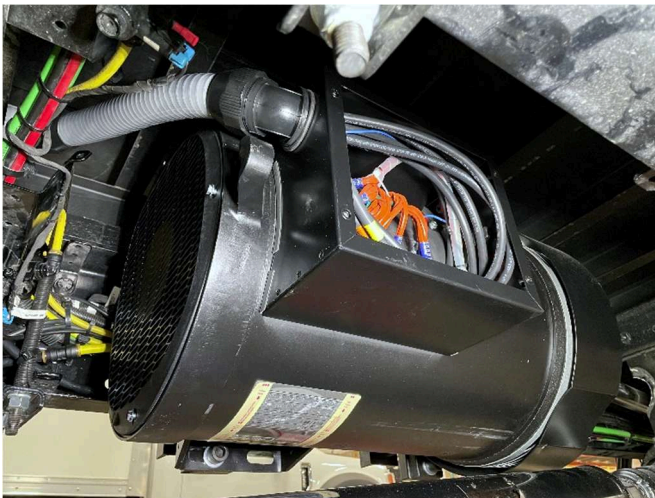

9. Carefully inspect the drive shaft for signs of deterioration, including missing balance weights, compromised welds or tubing, or cracks.



10. While every measure possible has been taken to secure the bolts and hardware on your generator system, vibration may cause them to loosen over time. Once per year, check and if necessary, retighten the fasteners per the following

- i. If PTO is a **Muncie FR3C**, follow this guide for torque requirements.

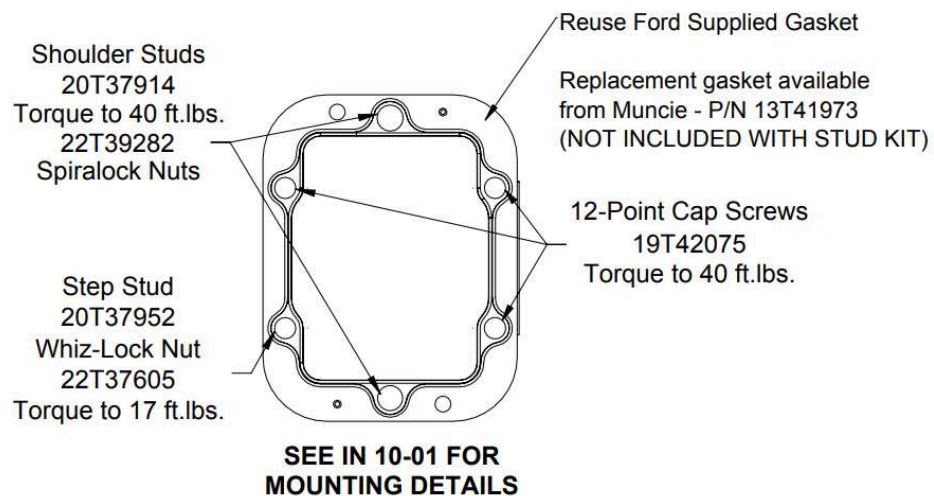

Reference:

https://www.munciepower.com/cms/files/Products/Literature/Documents/Service_Parts/SP16-03_FR3C_Service_Parts.pdf

- ii. If PTO is a **Muncie F20**, follow this guide for torque requirements.

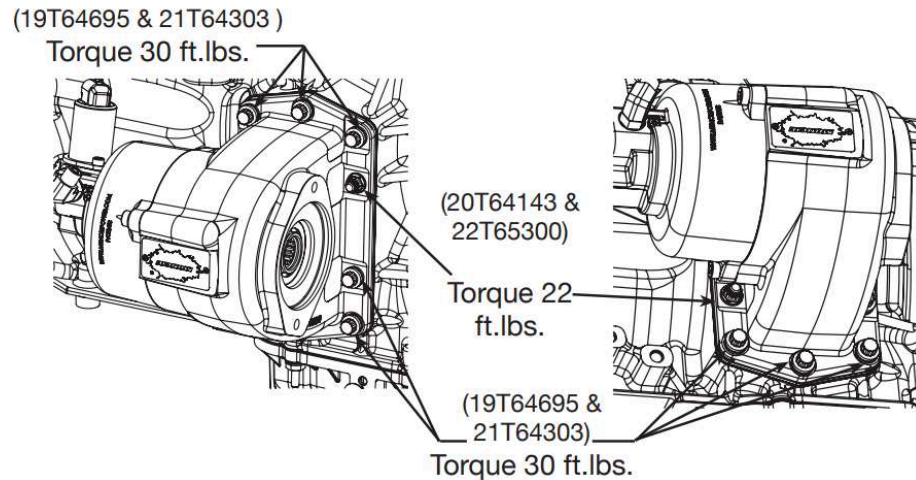

QTY.	PART NO.	DESCRIPTION
7	19T64695	PTO Mounting Bolt
7	21T64303	Flat Washer
2	20T64143	M10 x M8 Stud
2	22T65300	M8 Nut

Reference:

https://munciepower.com/cms/files/Products/Literature/Documents/Service_Parts/SP19-09.pdf

- iii. If PTO is a different 6 or 8 bolt Muncie, follow this description:

Torque all the mounting cap screws or nuts to 40–45 lb.ft., (6-Bolt pad) or 50–55 lb.ft., (8-Bolt pad) unless noted in a separate stud kit instruction. Failure to properly tighten capscrews or nuts can lead to leaks. PTO and/or transmission damage can occur. **Improper installation, tightening, or leaks are not the responsibility of Muncie Power Products, Inc.**

Recheck the backlash.

The PTO gear should not move more than .012 or less than .006 when all mounting nuts or bolts have been torqued.

Reference:

https://www.munciepower.com/cms/files/Products/Literature/Documents/Install/IN84-03_PTO_Operators_Manual-ENG.pdf

- iv. If PTO is a **Chelsea 210**, torque requirements are given as 24-28ft-lbs.

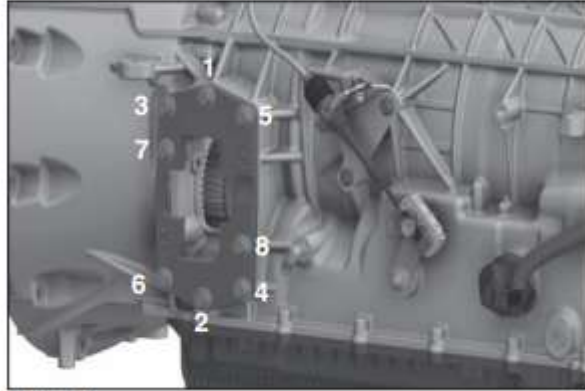
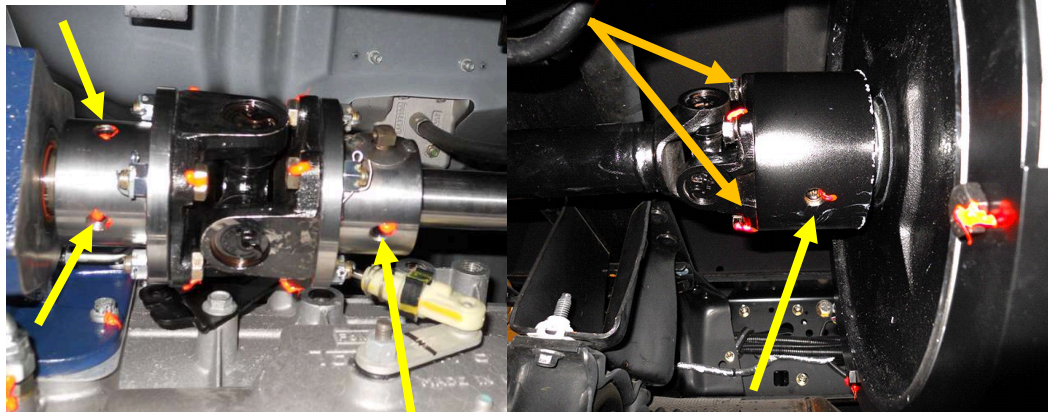

Figure 18

Reference:

https://www.parker.com/Literature/Chelsea%20Products%20Division/Owners%20Manual%20PDFs%20-%20Chelsea%20SA/HY25-1400-M1_US.pdf (page 10)

- v. Check tightness of the set screws on the PTO and generator side flanges of the driveline with 3/16" and 1/4" Allen driver (yellow arrows). Use a 5/8" wrench (RP100) or a 1/2" wrench (RP020) to snug up hex bolts on the generator input flange (orange arrows).



11. Once every year, check the power distribution panel. Hit the emergency stop switch on the panel exterior and then use a Phillips screw driver to open the panel door. Visually check each breaker and the wiring for discoloration, signs of heating, or broken connections. Close the panel and reset the emergency stop switch.

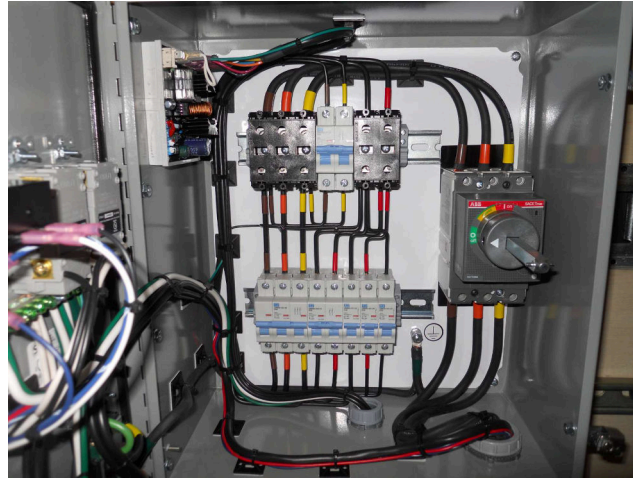

12. Plan on an engine oil change every 5000-7500 miles per the Severe Duty maintenance cycle by the manufacturer. The onboard Intelligent Oil-Life Monitor System will indicate when exactly a change is due.
13. A clogged fuel filter will rob your engine of horsepower and can cause substantial reductions to the stability of the electrical power coming out of the generator. The truck owner's manual indicates that the fuel filter should be changed every 15,000 – 25,000 miles. However, with a Real Power generator onboard, the hours on the generator count towards usage as well. Multiply the hour meter reading on the panel by a standard 50 miles/hr and add to the odometer miles to calculate the total. For example, a new truck with 10,000 miles and 200hrs on the generator would calculate like this:

$$10,000 \text{ miles} + (200 \text{ hrs} \times 50 \text{ miles/hr}) = 20,000 \text{ miles}$$

14. Follow the same procedure as above to calculate transmission miles for the purposes of transmission fluid replacement.

TROUBLE SHOOTING

In the event of an issue with your Real Power generator system, this guide will help identify and diagnose a root cause and potential solution. Phone assistance is available at (877) 670-7325



WARNING: When System is operating, lethal voltage is present. Working near rotating components is dangerous and carries risk of severe bodily harm or death. Troubleshooting should only be done by a trained technician and the system should always be shut down and de-energized to the fullest extent possible for each test.



Observation	Potential Cause	Potential Root Cause(s)	Action
Truck doesn't engage high idle	Generator Relay String	E-Stop, Over Temp Light, Parking Brake	Check and reset. If persistent, confirm 12V at PTO solenoid.
	SEIC Program	Park, Foot Brake, Accelerator	Check and reset. If persistent, check for possible bad sensors.
Truck high idle shuts down unexpectedly	Generator Relay String	E-Stop, Parking Brake, PTO Switch	Check and reset. If persistent, check for loose connections.
		Over Temp Switch	Check Over Temp indicator light. If on, clean the air filter on the generator.
	SEIC Program	Park, Foot Brake, Accelerator	Check and reset. If persistent, check for possible bad sensors.
		Transmission/Engine Temp Limits	Use dashboard to check Engine and Trans. Temp during operation.
		Vehicle Motion Detected	Confirm vehicle is not being shifted by external forces.
Vehicle calls for DPF regen	Take to dealership. Vehicle should be able to run a parked regen while in stationary PTO mode.		
High Idle On, but No or Extremely low Voltage	Circuit Breakers	Main Breaker, Sub Breakers	Check for power to panel meter (if present). Shut system down, remove keys from truck, and check inside panel for trips.
	Generator not Turning	PTO not Engaging	Confirm generator is stationary. Check for 12V present at solenoid. Work with Real Power to determine next steps.
		Driveline Failure	With vehicle off, inspect for broken or disconnected components, keyway. Do not move truck until system is secured from damaging vehicle transmission.
	Generator Regulator Failure	-	Use DSR manual to determine if power is on and potential error codes.
Generator Electrical Failure	Diodes, Stator, Exciter, Regulator	Contact Real Power for diagnostic support	
Incorrect Voltage +/-20%	Regulator Adjustment	-	Contact Real Power for procedure to adjust regulator Voltage
Incorrect Frequency - Consistent	Engine RPM Adjustment	-	Contact Real Power for procedure to adjust vehicle RPM
Incorrect Frequency - Transient	PTO Slippage	PTO Clutch	Evaluate generator frequency when different size loads are applied. Contact Real Power to determine possible replacement options.
Insufficient Power – Truck engine drops significantly when load applied.	Loss of Horsepower	Air Intake, Fuel Filter	Check and replace filters as needed.
		DPF, ECM Codes	Contact local dealership for evaluation
Insufficient Power – Truck engine stays mostly constant when load applied	Drive Shaft Keyway	-	Confirm by observing generator slowing down under load. Contact Real Power for driveline replacement options.
	PTO Clutch	Clutch Pack, PTO Relay Base, 12V Wiring Solenoid, Solenoid O-Ring	Contact Real Power for diagnostic and repair options.

ENVIRONMENTAL IMPACT ON ELECTRICAL PERFORMANCE

Performance of the System will vary depending on the ambient temperature and elevation of the area in which it is operated.

POWER VARIATIONS ACCORDING TO THE WORK ENVIRONMENT AND ALTITUDE					
ALTITUDE	AMBIENT TEMPERATURE				
	25° C 77° F	40° C 104° F	45° C 113° F	50° C 122° F	55° C 131° F
< 1000 m < 3281 feet	1.09	1	0.96	.093	.091
1000 – 1500 m 3281 – 4921 feet	1.01	0.96	0.92	0.89	.087
1500 – 2000 m 4921 – 6562 feet	0.96	0.91	0.87	0.84	0.83
2000 – 3000 m 6562 – 9843 feet	0.90	0.85	0.81	0.78	0.76

Multiply the above-listed power variation factor by the System's rated output to determine the environmentally adjusted output. For example, the environmentally adjusted output of the 12,000 watt rated system when used in Denver, Colorado on a warm sunny day (45°C/113°F) is calculated as follows: 12,000 rated output multiplied by the environmental factor of .87 (based on altitude in Denver (approximately 1600 m and ambient temperature of 45°C/113°F) = 10,440 watts.

UNAUTHORIZED AND UNTESTED USE - MISUSE



WARNING:

The Real Power chassis integrated AC generation system was not designed or intended for use in on-line control of devices or aircraft, air traffic, aircraft navigation or aircraft communications, or in the design, construction, operation or maintenance of any nuclear facility, or in the operation or maintenance of any life support system. Manufacturer and all Licensed Retailers-Installers disclaim any express or implied warranty of fitness for such uses. Users who elect to utilize the Real Power system for such purpose(s) assume all risks and liability associated therewith.